

# 2014 Upgrade Options

## Directly to R75

NGX R65  
 NGX R65 for SecurePlatform 2.6  
 NGX R65 for IPSO 6.2 (with HFA70 only)  
 NGX R65 Connectra NGX R66 Plug-in  
 NGX R65 with Messaging Security  
 NGX R65 VSX NGX R65 Management Plug-in  
 NGX R65.3  
 NGX R65 UTM-1/Power-1  
 NGX R65.40 \*no migration path\*  
**R65 Versions EOS August 2012**

R70, R70.1, R70.20, R70.30, R70.40 to R75  
 R70.50 migration path to R75.40 →  
**R70 Version EOS March 2013**

R71, R71.10, R71.20 to R75  
 R71.30 migration path to R75.20 →  
 R71.40/45 migration path to R75.40 →  
 R71.50 migration path to R76 only →  
**R71 Versions EOS April 2014**

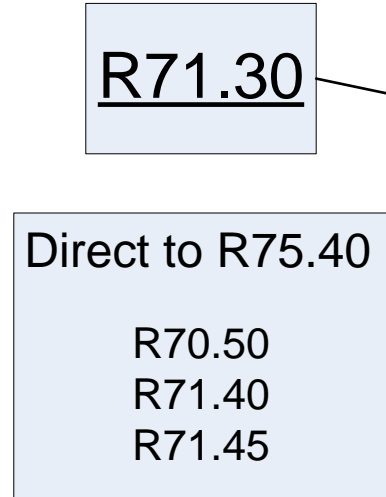
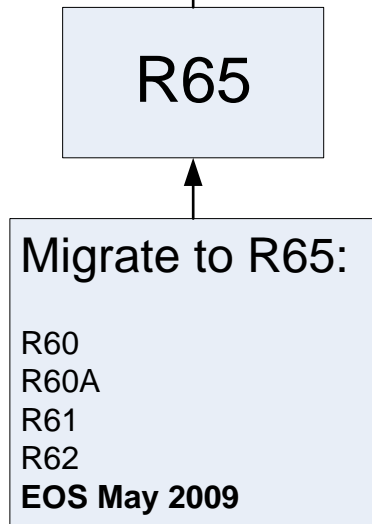

Only R75.40 and R75.45 can upgrade to R75.46

**fireverse**  
 Pat Waters  
 patw@fireverse.com  
 6/27/2014  
 © fireverse

[Click here for the latest version of this document](#)

[Check Point Software Support Timeline](#)

